

CT

1. CT Test

CT Test 가

가. CT 1 Open 가 .
 . CT 2 가 .
 . CT 2 (CT) .

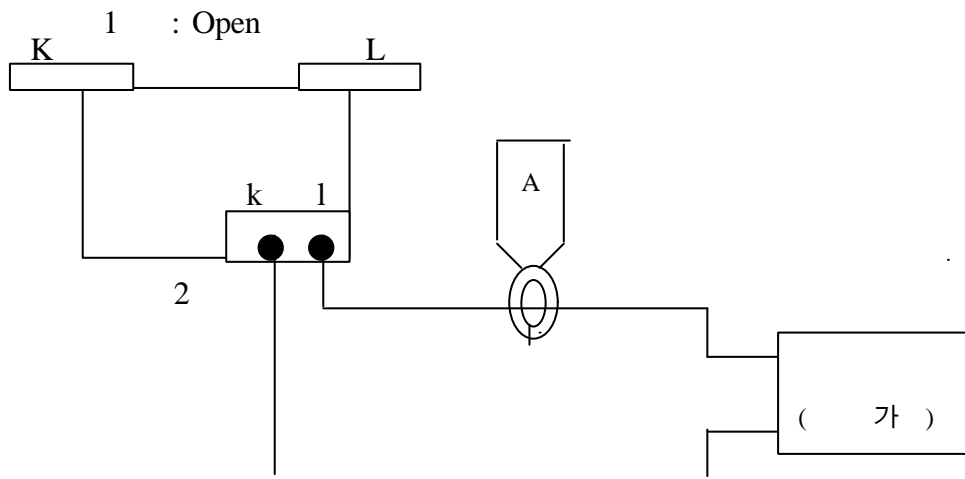

2. CT Plotting
 X Y 가 Plotting .

3. CT
 가. CT

1) Test CT : 2000/5A, 30VA, 5P20

2) CT CT 5P20
 1 (2000A) 20(20000A)가 2
 가 ±5% 가 .

3) (30VA)/ (5A)
 6V 20 (120V) 가 .

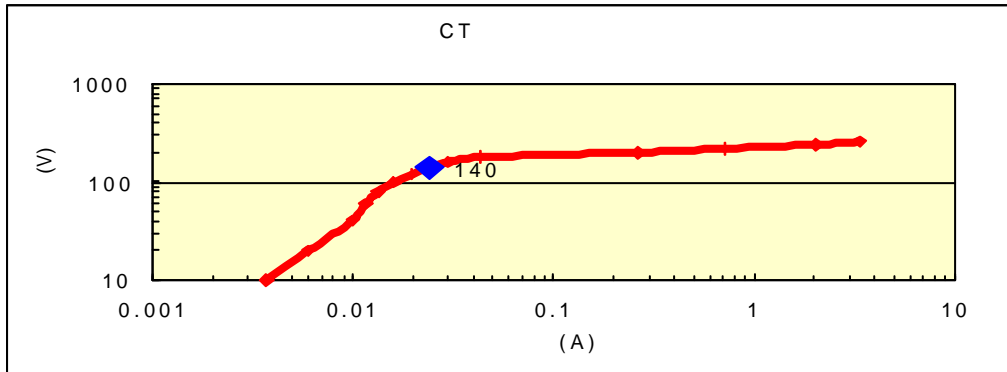

[1] (2000/5A, 30VA, 5P20) CT

4) [1] CT Test .
 CT 140V(23) 120V
 0.019A ()가 5P20 .

. Metering CT

1) Test CT : 1200/5A, 40VA, 1.0 Class

2) CT Metering 1.0 Class
 1 (1200A)가 2 가 ±1%
 가 .

3) Metering CT
 5

Meter .

4) CT (40VA)/ 8V
 5 (40V) .

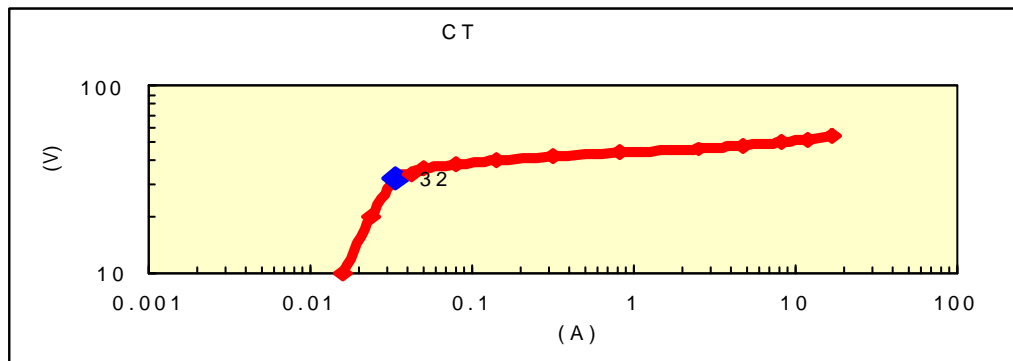

[2] Metering (1200/5A, 40VA, 1.0Class) CT

5) [2] Metering CT Test .
CT 32V(4) 10V 0.016A
가 1.0 Class .

4. 가 Metering CT
CT CT
/ Meter .